

IEEE Std 187™-2003
(Revision of
IEEE Std 187-1990)

IEEE Standards

187™

**IEEE Standard for Measurement
Methods of Emissions from FM and
Television Broadcast Receivers in the
Frequency Range of 9 kHz to 40 GHz**

IEEE Electromagnetic Compatibility Society

Sponsored by the
Standards Development Committee



Published by
The Institute of Electrical and Electronics Engineers, Inc.
3 Park Avenue, New York, NY 10016-5997, USA

7 May 2004

Print: SH95186
PDF: SS95186

Recognized as an
American National Standard (ANSI)

IEEE Std 187™-2003
(Revision of
IEEE Std 187-1990)

IEEE Standard for Measurement Methods of Emissions from FM and Television Broadcast Receivers in the Frequency Range of 9 kHz to 40 GHz

Sponsor

Standards Development Committee
of the
Electromagnetic Compatibility Society

Approved 12 December 2003

IEEE-SA Standards Board

Approved 31 March 2004

American National Standards Institute

Abstract: Spurious radiation from sound and television broadcast receivers of the superheterodyne type are possible sources of interference with other radio services. This standard describes the potential sources of spurious radiation from receivers intended for the reception of sound and television broadcast, and the measurement methods for them.

Keywords: antenna radiation, conducted emissions, FM sound broadcast receivers, radiated emissions, spurious emissions, television broadcast receivers

The Institute of Electrical and Electronics Engineers, Inc.
3 Park Avenue, New York, NY 10016-5997, USA

Copyright © 2004 by the IEEE.
All rights reserved. Published 7 May 2004. Printed in the United States of America.

IEEE is a registered trademark in the U.S. Patent & Trademark Office, owned by the Institute of Electrical and Electronics Engineers, Incorporated.

Print: ISBN 0-7381-3875-4 SS95186
PDF: ISBN 0-7381-3876-2 SS95186

No part of this publication may be reproduced in any form, in an electronic retrieval system or otherwise, without the prior written permission of the publisher.

IEEE Standards documents are developed within the IEEE Societies and the Standards Coordinating Committees of the IEEE Standards Association (IEEE-SA) Standards Board. The IEEE develops its standards through a consensus development process, approved by the American National Standards Institute, which brings together volunteers representing varied viewpoints and interests to achieve the final product. Volunteers are not necessarily members of the Institute and serve without compensation. While the IEEE administers the process and establishes rules to promote fairness in the consensus development process, the IEEE does not independently evaluate, test, or verify the accuracy of any of the information contained in its standards.

Use of an IEEE Standard is wholly voluntary. The IEEE disclaims liability for any personal injury, property or other damage, of any nature whatsoever, whether special, indirect, consequential, or compensatory, directly or indirectly resulting from the publication, use of, or reliance upon this, or any other IEEE Standard document.

The IEEE does not warrant or represent the accuracy or content of the material contained herein, and expressly disclaims any express or implied warranty, including any implied warranty of merchantability or fitness for a specific purpose, or that the use of the material contained herein is free from patent infringement. IEEE Standards documents are supplied “**AS IS.**”

The existence of an IEEE Standard does not imply that there are no other ways to produce, test, measure, purchase, market, or provide other goods and services related to the scope of the IEEE Standard. Furthermore, the viewpoint expressed at the time a standard is approved and issued is subject to change brought about through developments in the state of the art and comments received from users of the standard. Every IEEE Standard is subjected to review at least every five years for revision or reaffirmation. When a document is more than five years old and has not been reaffirmed, it is reasonable to conclude that its contents, although still of some value, do not wholly reflect the present state of the art. Users are cautioned to check to determine that they have the latest edition of any IEEE Standard.

In publishing and making this document available, the IEEE is not suggesting or rendering professional or other services for, or on behalf of, any person or entity. Nor is the IEEE undertaking to perform any duty owed by any other person or entity to another. Any person utilizing this, and any other IEEE Standards document, should rely upon the advice of a competent professional in determining the exercise of reasonable care in any given circumstances.

Interpretations: Occasionally questions may arise regarding the meaning of portions of standards as they relate to specific applications. When the need for interpretations is brought to the attention of IEEE, the Institute will initiate action to prepare appropriate responses. Since IEEE Standards represent a consensus of concerned interests, it is important to ensure that any interpretation has also received the concurrence of a balance of interests. For this reason, IEEE and the members of its societies and Standards Coordinating Committees are not able to provide an instant response to interpretation requests except in those cases where the matter has previously received formal consideration. At lectures, symposia, seminars, or educational courses, an individual presenting information on IEEE standards shall make it clear that his or her views should be considered the personal views of that individual rather than the formal position, explanation, or interpretation of the IEEE.

Comments for revision of IEEE Standards are welcome from any interested party, regardless of membership affiliation with IEEE. Suggestions for changes in documents should be in the form of a proposed change of text, together with appropriate supporting comments. Comments on standards and requests for interpretations should be addressed to:

Secretary, IEEE-SA Standards Board
445 Hoes Lane
P.O. Box 1331
Piscataway, NJ 08855-1331USA

NOTE—Attention is called to the possibility that implementation of this standard may require use of subject matter covered by patent rights. By publication of this standard, no position is taken with respect to the existence or validity of any patent rights in connection therewith. The IEEE shall not be responsible for identifying patents for which a license may be required by an IEEE standard or for conducting inquiries into the legal validity or scope of those patents that are brought to its attention.

Authorization to photocopy portions of any individual standard for internal or personal use is granted by the Institute of Electrical and Electronics Engineers, Inc., provided that the appropriate fee is paid to Copyright Clearance Center. To arrange for payment of licensing fee, please contact Copyright Clearance Center, Customer Service, 222 Rosewood Drive, Danvers, MA 01923 USA; +1 978 750 8400. Permission to photocopy portions of any individual standard for educational classroom use can also be obtained through the Copyright Clearance Center.

Introduction

(This introduction is not part of IEEE Std 187-2003, IEEE Standard for Measurement Methods of Emissions from FM and Television Broadcast Receivers in the Frequency Range of 9 kHz to 40 GHz.)

This standard is a revision of IEEE Std 187-1990 IEEE, Standard on Radio Receivers: Open Field Method of Measurement of Spurious Radiation from FM and Television Broadcast Receivers, and IEEE Std 213™-1987, IEEE Standard Procedure for Measuring Conducted Emissions in the Range of 300 kHz to 25 MHz from Television and FM Broadcast Receivers to Power Lines.

This standard is specifically written to outline the procedures for testing television (NTSC and ATSC) and FM broadcast receivers.

Notice to users

Patents

Attention is called to the possibility that implementation of this standard may require use of subject matter covered by patent rights. By publication of this standard, no position is taken with respect to the existence or validity of any patent rights in connection therewith. The IEEE shall not be responsible for identifying patents or patent applications for which a license may be required by to implement an IEEE standard or for conducting inquiries into the legal validity or scope of those patents that are brought to its attention.

Errata

Errata, if any, for this and all other standards can be accessed at the following URL: <http://standards.ieee.org/reading/ieee/updates/errata/index.html>. Users are encouraged to check this URL for errata periodically.

Interpretations

Current interpretations can be accessed at the following URL: <http://standards.ieee.org/reading/ieee/interp/index.html>.

Participants

At the time this standard was completed, the 187 Working Group had the following membership:

David L. Traver, *Chair*

Risaburo Sato, *Vice Chair*

Mark Arthurs, *Secretary*

Brian Cromarty
Joseph DiBiase
Eugene Janson
Jon Kanter

Ted Marks
Tom Mock
Richard Mullen
Wayne M. Myrick
Kenji Okazaki

Mark S Schuyler
Akira Sugiura
Rolly U. Velbis
Dave Wilson

When the IEEE-SA Standards Board approved this standard on 12 December 2003, it had the following membership:

Don Wright, *Chair*
Howard M. Frazier, *Vice Chair*
Judith Gorman, *Secretary*

H. Stephen Berger
Joe Bruder
Bob Davis
Richard DeBlasio
Julian Forster*
Toshio Fukuda
Arnold M. Greenspan
Raymond Hapeman

Donald M. Heirman
Laura Hitchcock
Richard H. Hulett
Anant Jain
Lowell G. Johnson
Joseph L. Koepfinger*
Tom McGean
Steve Mills

Daleep C. Mohla
William J. Moylan
Paul Nikolich
Gary Robinson
Malcolm V. Thaden
Geoffrey O. Thompson
Doug Topping
Howard L. Wolfman

*Member Emeritus

Also included are the following nonvoting IEEE-SA Standards Board liaisons:

Satish K. Aggarwal, *NRC Representative*
Richard DeBlasio, *DOE Representative*
Alan Cookson, *NIST Representative*

Don Messina
IEEE Standards Project Editor

Contents

1. Overview.....	1
1.1 Scope.....	1
2. References.....	1
3. Definitions	2
4. Sources of spurious emissions	2
5. Modes of spurious emissions	3
6. Method of measurement (conducted emissions)	3
6.1 General.....	3
6.2 Equipment required and setup details	3
6.3 Measurement procedure.....	8
7. Method of measurement (radiated emissions)	8
7.1 General.....	8
7.2 Equipment required and setup details	8
7.3 Measurements procedure	12
8. Antenna radiation (local oscillator measurement)	13
Annex A (informative) General TV test requirements.....	14
Annex B (informative) Bibliography	15

IEEE Standard for Measurement Methods of Emissions from FM and Television Broadcast Receivers in the Frequency Range of 9 kHz to 40 GHz

1. Overview

This standard is divided into three types of testing: Conducted Emissions (Clause 6), Radiated Emissions (Clause 7), and Antenna Radiation (Clause 8). The standard also includes two informative annexes entitled “General TV Test Requirements” and “Bibliography.”

1.1 Scope

Spurious radiation from sound and television broadcast receivers of the superheterodyne type are possible sources of interference with other radio services.

This standard describes the potential sources of spurious radiation from receivers intended for the reception of sound and television broadcast, and the measurement methods for them.

2. References

This standard shall be used in conjunction with the following publications. When the following specifications are superseded by an approved revision, the revision shall apply.

ANSI C63.2-1996, American National Standard for Electromagnetic Noise and Field Strength, 10 kHz to 40 GHz Specifications.¹

ANSI C63.4-2001 American National Standard for Methods of Measurement of Radio-Noise Emission from Low-Voltage Electrical and Electronic Equipment in the Range of 9 kHz to 40 GHz.

Code of Federal Regulations (CFR) Title 47, Part 15.²

¹ANSI publications are available from the Sales Department, American National Standards Institute, 25 West 43rd Street, 4th Floor, New York, NY 10036, USA (<http://www.ansi.org/>).

²Code of Federal Regulations (CFR) documents are available from the U.S. Government Printing Office, 732 N. Capitol Street NW, Washington, DC 20401 (<http://bookstore.gpo.gov/>).

CISPR 16-1 (2002-10) Ed. 2.1 Consolidated Edition Specification for radio disturbance and immunity measuring apparatus and methods—Part 1: Radio disturbance and immunity measuring apparatus.³

CISPR 22 (2003) Ed. A Information technology equipment—Radio disturbance characteristics—Limits and methods of measurement.

ITU-R BT.471-1 (07/86), Nomenclature and description of color bar signals.⁴

3. Definitions

For the purposes of this standard, the following terms and definitions apply. *The Authoritative Dictionary of IEEE Standards Terms*, Seventh Edition [B1],⁵ ANSI C63.4,⁶ and CFR 47 Part 15 should be referenced for terms not defined in this clause.

3.1 frequency modulation (FM) sound broadcast receiver: A device designed to receive FM sound broadcast from a licensed station on frequencies that are authorized for commercial or public broadcasting.

3.2 television (TV) broadcast receiver: A device designed to receive television pictures that are broadcast simultaneously with sound from a licensed station on frequencies that are authorized for commercial or public broadcasting.

4. Sources of spurious emissions

Possible sources of spurious emissions typically found in TV and FM receivers are as follows:

- a) The local oscillator circuits, which may radiate fundamental, harmonics, and intermodulation products formed from the local oscillator fundamental and harmonics.
- b) Intermediate frequency amplifier, which may radiate spurious signals at the fundamental and harmonics of the intermediate frequency.
- c) In some television receivers, the high-voltage circuits for the cathode-ray tube incorporate radio frequency oscillators, which may be a potential source of radiation at fundamental and harmonic frequencies.
- d) In television receivers, the sweep circuits, which may radiate harmonics of their fundamental frequencies.
- e) In television receivers, the video amplifier and any nonlinear circuit element that may produce signals by demodulation of radio or intermediate frequency signals.
- f) Digital circuits incorporated for a channel display, or processing of digital wanted signals, or any other digital control circuit.

³CISPR documents are available from the International Electrotechnical Commission, 3, rue de Varembe, Case Postale 131, CH 1211, Genève 20, Switzerland/Suisse (<http://www.iec.ch/>). They are also available in the United States from the Sales Department, American National Standards Institute, 11 West 42nd Street, 13th Floor, New York, NY 10036, USA.

⁴ITU-T publications are available from the International Telecommunications Union, Place des Nations, CH-1211, Geneva 20, Switzerland/Suisse (<http://www.itu.int/>).

⁵The numbers in brackets correspond those in the bibliography in Annex B.

⁶Information on references can be found in Clause 2.

5. Modes of spurious emissions

Possible modes of spurious emissions from sources enumerated in Clause 4 are as follows:

- a) Spurious radiation signals emanating from any internal source, such as those described in Clause 4, may appear on the receiver antenna terminal(s) and be radiated from antenna systems attached thereto. Such signals may be balanced or unbalanced to ground.
- b) Radiation from the sources enumerated in Clause 4 may appear in the vicinity of the receiver due to direct electric fields or magnetic fields or both, created by the components assembled on or within the chassis or by cavity resonance.
- c) Radiation from any of the sources may be propagated through the power supply cord and any peripherals that may be attached to the receiver. Such radiation may be due to balanced or unbalanced current in the power cord or connection leads.

6. Method of measurement (conducted emissions)

6.1 General

Television and FM broadcast receivers are potential sources of interference to other television and FM broadcast receivers, receivers in other services, and other electronics. This section of the standard defines a method for obtaining a measure of the emissions conducted by the power line from these potential interference sources in the frequency range of 150 kHz to 30 MHz. This section of the standard describes standard input signals, the equipment setup, and measurement techniques.

6.2 Equipment required and setup details

6.2.1 Test signal

The standard test signal for FM radio receivers is an RF signal modulated with a 1 kHz tone. A digital sound signal is a RF signal modulated with a digital data stream containing sound information.

The standard test signal for television receivers is a standard television color bar signal according to ITU-R BT 471-1. The input signal shall be a vision carrier modulated by a complete video waveform, including a color burst together with an unmodulated sound carrier of the correct relative amplitude and frequency. A digital television signal is a RF signal modulated with a digital data stream containing video and accompanying sound information.

For analog sound and television receivers, the input level of the test signal at the antenna terminal of the equipment under test (hereafter referred to as EUT) is sufficiently strong to provide a noise-free picture.

The input level of the digital sound signal at the antenna terminal of the EUT is 60 dB μ V. The input levels of the digital television signals at the antenna terminal of the EUT for 75 Ω impedance connectors are 50 dB μ V (VHF) and 54 dB μ V (UHF) for terrestrial systems.

6.2.2 Supply of the standard test signal

The standard test signal as defined in 6.2.1 shall be supplied to the EUT through a 50 to 75 Ω antenna isolation transformer. This isolation transformer, details of which are shown in Figures 1–3, is designed to have an impedance of 50 Ω unbalanced for the input terminal and 75 Ω unbalanced for the output terminal.

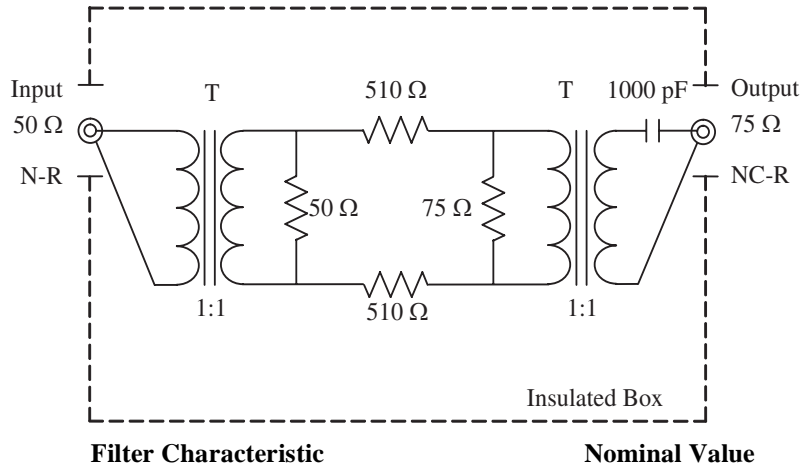

Filter Characteristic	Nominal Value
Frequency Band:	46 MHz to 1.5 GHz
Insertion Loss:	30 dB \pm 2dB
Input Impedance:	50 Ω
Input Connector:	N-R
Output Impedance:	75 Ω
Output Connector:	NC-R
Chassis:	Insulated Material

Figure 1—Isolation transformer for 46 MHz to 1.5 GHz

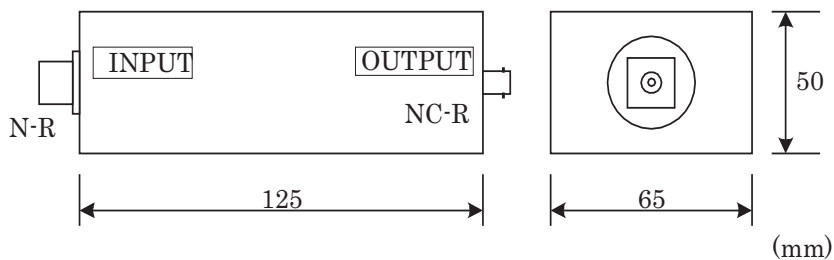

Figure 2—Typical size of isolation transformer for 46 MHz to 1.5 GHz

If the receiver has a built-in antenna and external antenna terminal, the built-in antenna shall be disconnected from the antenna terminal during these tests.

If the receiver has no external antenna terminal and only a built-in antenna, the standard RF input signal is supplied at a sufficiently strong level to provide a noise-free picture to the receiver through a radiating antenna.

When the receiver is designed only to have an impedance of $300\ \Omega$ balanced, the RF signal shall be supplied to the receiver through a suitable impedance transformer (e.g., 75 to $300\ \Omega$).

When the receiver has more than one tuner or a combination of analog and digital tuners, all reception modes shall be investigated, i.e., analog input, digital input, or combination of inputs. The reception mode with the highest emission with respect to the applicable emission limit shall be recorded.

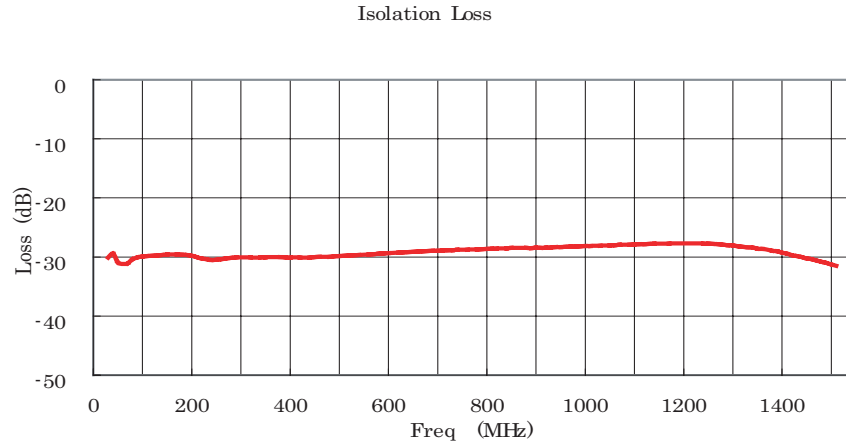

Figure 3—Typical characteristic of insertion loss of isolation transformer for 46 MHz to 1.5 GHz

6.2.3 Adjustment of operating controls

The customer-operated controls of the receiver with the exception of the tuning adjustments and controls of contrast, brightness, and color saturation for TV receivers shall be at center or neutral position. The controls of contrast, brightness, and color saturation for TV receivers shall be set to produce a normal picture. This is obtained with the following luminance values:

- Black part of the test pattern: $2\ \text{cd/m}^2$
- Magenta part of the test pattern: $30\ \text{cd/m}^2$
- White part of the test pattern: $80\ \text{cd/m}^2$

The luminance of the magenta part of the test pattern should be set to $30\ \text{cd/m}^2$. If this level cannot be reached, the luminance should be set to the maximum possible. If a value different from $30\ \text{cd/m}^2$ is used, it shall be stated together with the results.

6.2.4 RF voltmeter

An RF voltmeter conforming to ANSI C63.2 or CISPR 16-1 shall be used. Other measuring equipment may be used if the measurements correlate to those obtained by the RF voltmeter as specified in ANSI C63.2 or CISPR 16-1.

6.2.5 Line impedance stabilization network (LISN)

The purpose of this network is to present a standard value of power line impedance to the EUT regardless of the local power-line conditions. An LISN conforming to ANSI C63.4 or CISPR 22 shall be used.

6.2.6 Measurement site

The measurement site shall meet the “Test Facilities” requirements in ANSI C63.4, CISPR 16-1, and CISPR 22, for both conducted emission and radiated emission measurements.

6.2.7 Arrangement of EUT

Table-top models shall be placed on a nonmetallic platform 80 cm above the floor. The preferred size of the table-top platform is 1 m by 1.5 m, but it may be enlarged, if necessary, to allow for large systems. The rear side of the receiver shall be positioned at 40 cm distance from the vertical conductive surface, and all other sides shall be a minimum of 80 cm from other conductive surfaces. Floor-standing models shall be placed on the floor. The power-line impedance stabilization network shall be located a minimum of 80 cm from the cabinet of the EUT. The RF signal generator producing the standard test signal as defined in 6.2.1 shall be connected to the antenna input terminal of the EUT through an isolation transformer specified in Figure 1, Figure 2, and Figure 3 or as specified in 6.2.2 for EUT without antenna terminal. The standard arrangement is shown in Figure 4 and Figure 5.

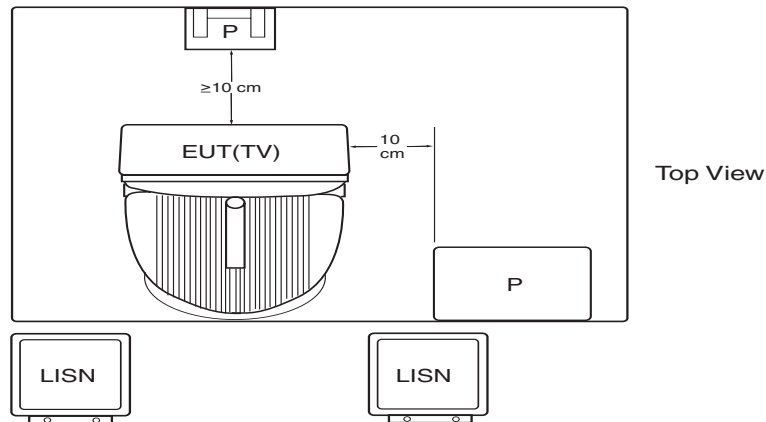
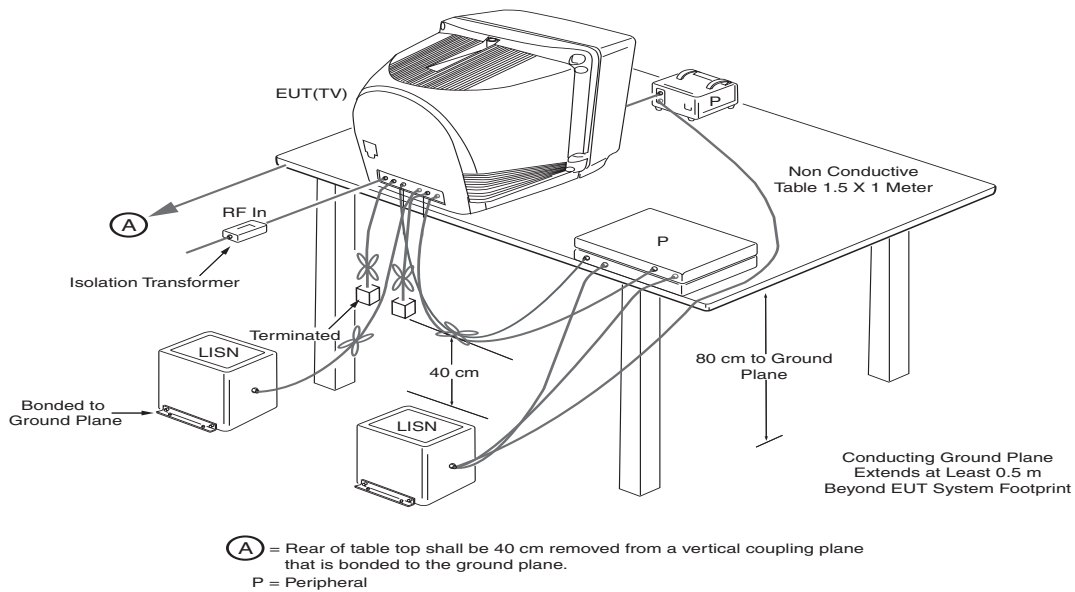

Figure 4—Test arrangement for conducted emissions (table-top equipment)

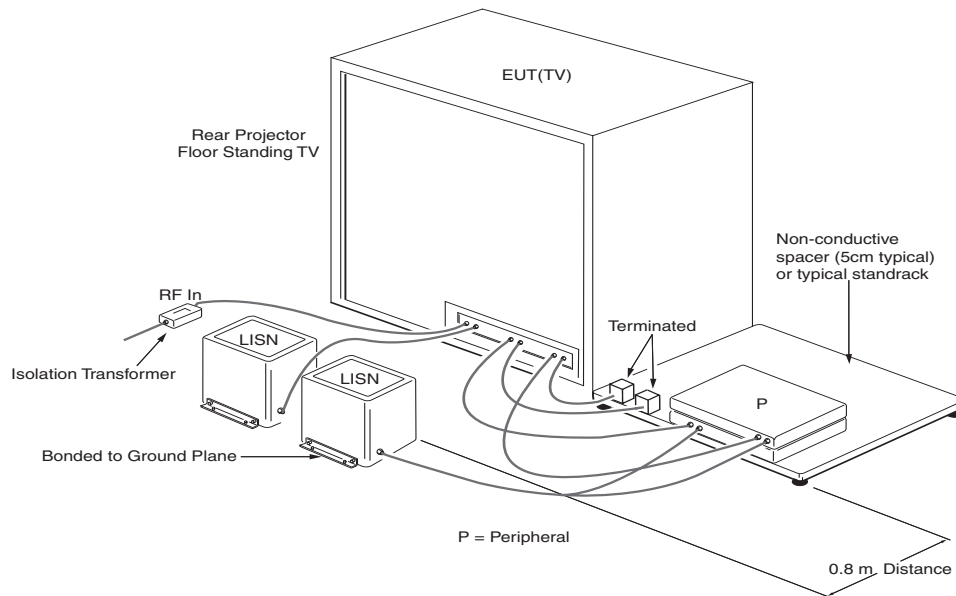

Figure 5—Test arrangement for conducted emissions (floor-standing equipment)

The power-line impedance stabilization network shall be bonded to the metallic floor.

The mains lead shall be arranged to follow the shortest possible path between the receiver and power-line impedance stabilization network on the floor. The mains lead in excess of 80 cm separating the EUT from the power-line impedance stabilization network shall be folded back and forth parallel to the lead so as to form a bundle with a length of 30 cm to 40 cm.

Earthing of the EUT if provided with a safety earth connection shall be made to the earth terminal provided on the power-line impedance stabilization network with the shortest possible lead.

6.2.8 EUT ports (and terminals)

Interface cables/loads/devices shall be connected to at least one of each type of interface port of the EUT. Where practical, each cable connected to a digital port shall be terminated in a device typical of actual usage. Interface cables connected to analog ports shall be terminated by a noninductive resistor equal to the value of the nominal impedance for the port or terminated in a device typical of actual usage. Manufacturer-supplied interface cabling or wiring shall be used, or if none is supplied, the cable shall be commercially available and a minimum of 1 m in length. Interface cables of table-top EUTs that hang closer than 40 cm to the ground plane shall be folded back and forth forming a bundle 30 to 40 cm long and hanging approximately in the middle between ground plane and table.

6.2.9 Placement of table-top accessories/peripherals

Accessories/peripherals that are part of a system tested on a table top shall be placed in a test arrangement on one or both sides of the host with a minimum of 10 cm separation between the nearest points of the cabinets (see Figure 4 and Figure 5).

The rear of the EUT and accessories shall be flush with the back of the supporting table top unless that would not be typical of normal use. If more than two accessories are present, an equipment test arrangement

should be chosen that maintains a minimum of 10 cm spacing between cabinets unless the equipment is normally located closer together.

Multiple peripherals/accessories (more than two) may be distributed around the table as shown in Figure 4. If the EUT peripherals are designed to be stacked in typical use, they shall be stacked.

Accessories, such as ac power adapters, which are typically table-mounted because of cable length, shall be mounted on the table top in a typical manner.

Accessories, which are typically floor-mounted, shall occupy a floor position directly below the portion of the table-top EUT to which they are typically connected.

6.2.10 Placement of floor-standing accessories/peripherals

Accessories/peripherals that are part of a floor-standing system shall be placed in one typical arrangement with typical spacing between equipment cabinets or enclosures as shown in Figure 5. If more than two accessories are present, a typical arrangement should be chosen that maintains typical spacing between all equipment cabinets or enclosures.

6.3 Measurement procedure

With the tuned voltmeter connected to one 50 Ω output of the power-line impedance stabilization network, as shown in Figure 4 (for table-top equipment) or Figure 5 (for floor-standing equipment), the voltage between this side of the power line and earth ground is measured at the frequencies of interest. The measurement is repeated with the voltmeter connected to the other 50 Ω terminal of the power-line impedance stabilization network.

6.3.1 Recording of measured data

Of those disturbances above (L-20 dB), where L is the limit level in logarithmic units, record at least the disturbance levels and the frequencies of the six highest disturbances. The emission voltage is recorded separately for each side of the power line at each frequency of interest. Provide measurement uncertainty data if applicable. (See ISO/IEC 17025 for guidance.)

7. Method of measurement (radiated emissions)

7.1 General

This section of the standard defines a system whereby emissions described in Clause 5 and Clause 6 may be measured. It also establishes operating conditions and equipment specifications necessary for accomplishing these measurements. In this method, the receiver and measuring equipment are set up under reproducible conditions, as described below, and the field strength of the various radiations is measured under specified conditions. This method is applicable to the measurement of spurious radiation in the frequency range of 30 MHz to 5000 MHz. For radiation in other bands, other methods of measurement may be necessary.

7.2 Equipment required and setup details

7.2.1 Test signal

The standard test signal for FM radio receivers is a RF signal modulated with a 1 kHz tone. A digital sound signal is a RF signal modulated with a digital data stream containing sound information.

The standard test signal for television receivers and for other equipment with video signal input/output or a RF modulator is a standard television color bar signal according to ITU-R BT 471-1. The wanted signal shall be a vision carrier modulated by a complete video waveform, including a color burst together with an unmodulated sound carrier of the correct relative amplitude and frequency. A digital television signal is a RF signal modulated with a digital data stream containing video and accompanying sound information.

For analog sound and television receivers, the input level of the test signal at the antenna terminal of the EUT is sufficiently strong to provide a noise-free picture.

The input level of the digital sound signal at the antenna terminal of the EUT is 60 dB μ V. The input levels of the digital television signals at the antenna terminal of the EUT for 75 Ω impedance connectors are 50 dB μ V (VHF) and 54 dB μ V (UHF) for terrestrial systems.

7.2.2 Supply of the standard test signal

The signal generator to generate a standard test signal shall be placed below the ground plane or on the ground plane underneath the EUT (in this case, shielding of the signal generator may be necessary to ensure that emissions from the signal generator do not impede the measurement). A standard test signal specified in 7.2.1 is supplied to the EUT from the signal generator via the shortest possible coaxial cable. The EUT shall be tuned to the standard test signal. For EUT with a built-in antenna and no external antenna terminal, the built-in antenna shall be used and the test signal obtained from a vertical transmitting antenna connected to the signal generator. This antenna shall not be closer than 3 m from the built-in antenna of the EUT and at least 6 m from the antenna connected to the field-strength meter, measured as horizontal distance.

Telescopic antennas shall be pulled out to their maximum lengths and fixed in a vertical position if there is a single rod, and in a position 45 degrees from the vertical forming an approximate V if there are two rods.

When the receiver has more than one tuner or a combination of analog and digital tuners, all reception modes shall be investigated, i.e., analog input, digital input, and combination inputs. The reception mode with the highest emission with respect to the applicable emission limit shall be recorded.

7.2.3 Adjustment of operating controls

The customer-operated controls of the receiver with the exception of the tuning adjustments and controls of contrast, brightness, and color saturation for TV receivers shall be at a center or neutral position. The controls of contrast, brightness, and color saturation for TV receivers shall be set to produce a normal picture. This is obtained with the following luminance values:

- Black part of the test pattern: 2 cd/m²
- Magenta part of the test pattern: 30 cd/m²
- White part of the test pattern: 80 cd/m²

The luminance of the magenta part of the test pattern should be set to 30 cd/m². If this level cannot be reached, the luminance should be set to the maximum possible. If a value different from 30 cd/m² is used, it shall be stated together with the results.

7.2.4 RF voltmeter

A RF voltmeter conforming to ANSI C63.2 or CISPR 16-1 or the latest revision thereof shall be used. Other measuring equipment may be used if the measurements correlate to those obtained by the RF voltmeter as specified in ANSI C63.2 or CISPR 16-1.

7.2.5 Antenna

The antenna used with the RF voltmeter shall be a half-wave tuned dipole antenna capable of being adjusted for horizontal or vertical polarization. Between 30 MHz and 80 MHz, a dipole having a constant length corresponding to $\lambda/2$ at 80 MHz shall be used as noted in CISPR 22. Other types of antennas may be used if the measurements correlate to those obtained by a half-wave tuned dipole antenna and that conform to ANSI C63.4 or CISPR 22 antenna requirements.

7.2.6 Distance between EUT and antenna

The antenna shall be located at a distance of 3 m horizontally from the periphery of the EUT. The 3 m distance is measured between the vertical projection onto the groundplane of the closest periphery of the EUT and the vertical projection onto the groundplane of the center of the axis of the elements of the receiving antenna. However, if the receiving antenna is a log-periodic array, the 3 m distance shall be measured between the closest periphery of the EUT and the front-to-back center of the array of elements.

If a 3 m distance measurement is not practical, a 10 m or a 30 m distance measurement may be used, provided that an inverse proportionality factor of 20 dB/decade is used and the antenna height is varied from 1 m to 4 m above the ground (3 m or 10 m distances) or 2 m to 6 m (30 m distance) searching for highest maximum.

7.2.7 EUT ports (and terminals)

Interface cables/loads/devices shall be connected to at least one of each type of interface port of the EUT. Where practical, each cable connected to a digital port shall be terminated in a device typical of actual usage. Interface cables connected to analog ports shall be terminated by a noninductive resistor equal to the value of the nominal impedance for the port or terminated in a device typical of actual usage. Manufacturer-supplied interface cabling or wiring shall be used, or if none is supplied, the cable shall be commercially available and a minimum of 1 m in length. Interface cables of table-top EUTs that hang closer than 40 cm to the ground plane shall be folded back and forth forming a bundle 30 cm to 40 cm long and hanging approximately in the middle between the ground plane and the table.

7.2.8 Arrangement of EUT

For table-top equipment, the EUT shall be placed on a rotating nonconducting table, the top of which is 80 cm above the ground, as shown in Figure 6. The preferred size of the table-top platform is 1 m by 1.5 m, but it may be enlarged, if necessary, to allow for large systems. In the event that the EUT does not fit on the table, such as may be the situation for console receivers, the EUT may be placed on the ground plane or on a TV manufacturer-supplied TV stand. Large rear projection receivers shall be placed on the ground plane as shown in Figure 7.

FM or television tuners and set-top box (STB) do not need to be measured together with a display monitor.

In the case of tuner cards for personal computers (PCs), separately marketed for incorporation in PCs, the card shall be tested in at least one appropriate representative PC chosen by the manufacturer.

7.2.9 Placement of table-top accessories/peripherals

Accessories/peripherals that are part of a system tested on a table top shall be placed in a test arrangement on one or both sides of the EUT with a minimum of 10 cm separation between the nearest points of the cabinets (see Figure 6).

The rear of the EUT and accessories/peripherals should be flush with the back of the supporting table top unless that would not be typical of normal use. If more than two accessories are present, an equipment test

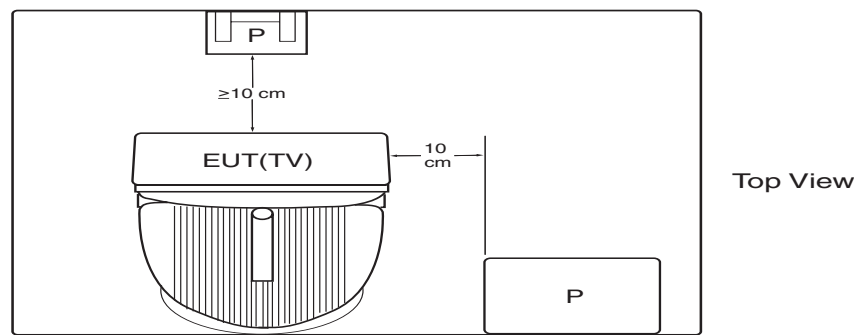
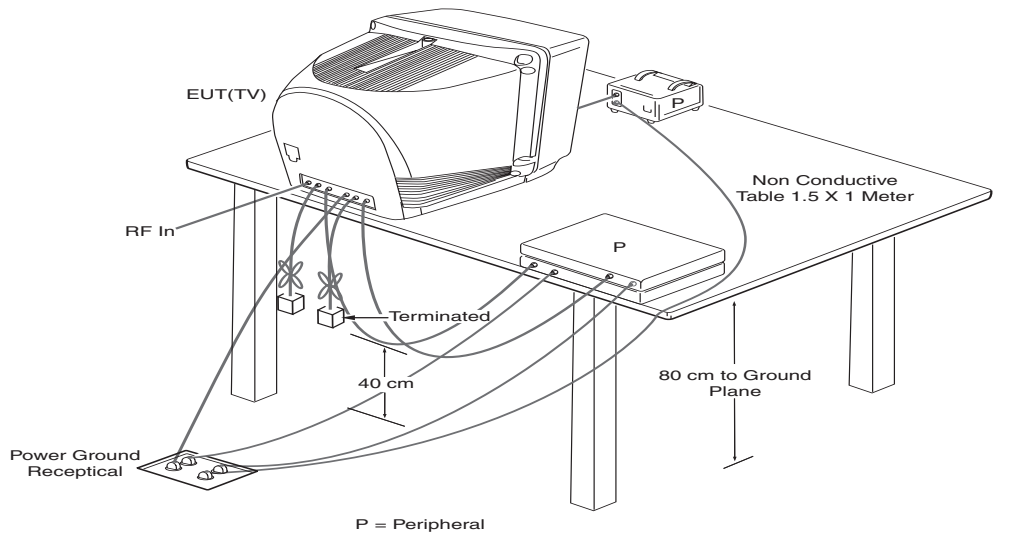

Figure 6—Test arrangement for radiated emissions (table-top equipment)

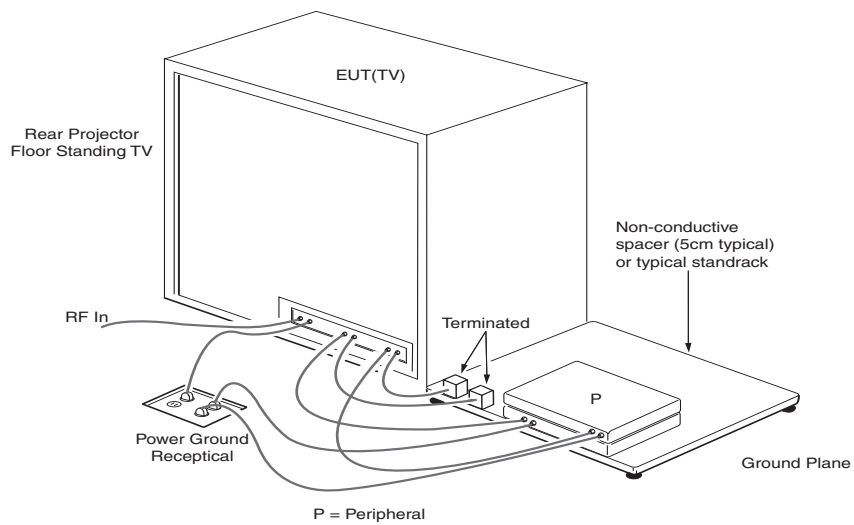

Figure 7—Test arrangement for radiated emissions (floor-standing equipment)

arrangement should be chosen that maintains a minimum of 10 cm spacing between cabinets unless the equipment is normally located closer together.

Multiple accessories/peripherals (more than two) may be distributed around the table as shown in Figure 6. If the EUT peripherals are designed to be stacked in typical use, they shall be stacked.

Accessories/peripherals, such as ac power adapters, which are typically table-mounted because of cable length, shall be mounted on the table top in a typical manner.

Accessories/peripherals, which are typically floor-mounted, shall occupy a floor position directly below the portion of the EUT to which they are typically connected.

7.2.10 Placement of floor-standing accessories/peripherals

Accessories/peripherals that are part of a floor-standing system shall be placed in one typical arrangement with typical spacing between equipment cabinets or enclosures as shown in Figure 7. If more than two accessories/peripherals are present, a typical arrangement should be chosen that maintains typical spacing between all equipment cabinets or enclosures.

7.2.11 Power supply

It is preferred that power lines be placed underneath the metallic ground plane and the receptacles flush with the ground plane.

The power supply cord of the EUT shall be oriented vertically and shall be as short as possible. Any excess length shall be left unbundled on the floor. Adequate isolation or filters shall be incorporated in the supply line to the EUT so that a negligible amount of signal will appear at the field-strength meter from this source. Each side of the line shall be bypassed to the conduit at the receiver outlet.

Unless otherwise specified, the line voltage shall be maintained in all measurements at within 5% of the line voltage specified by the manufacturer for use during normal receiver operation.

7.2.12 Measurement site

The measurement site shall meet the “Test Facilities” requirements in ANSI C63.4, CISPR 16-1, and CISPR 22.

7.3 Measurements procedure

The EUT shall be measured in the frequency range as required by the appropriate regulatory authority. The number of test frequencies shall be adequate to ensure measurement of maximum emission levels within this range.

The RF voltmeter shall be tuned to the frequency of the spurious radiation being measured.

The antenna is adjusted for horizontal polarization and the height is adjusted between 1 m and 4 m until the first maximum reading is obtained. The EUT is then rotated until the second maximum reading is obtained, after that the antenna height is again varied between 1 m and 4 m until third maximum reading is obtained (the first, second, and third maximum readings may be same), and the maximum reading is noted. The procedure is repeated for vertical polarization of the measuring antenna.

7.3.1 Recording of measured data

Of those disturbances above ($L-20$ dB), where L is the limit level in logarithmic units, record at least the disturbance levels and the frequencies of the six highest disturbances. Record the antenna polarization for each reported disturbance. Provide Measurement Uncertainty data if applicable. (See ISO/IEC 17025 for guidance.)

8. Antenna radiation (local oscillator measurement)

Antenna-conducted power measurements shall be performed on each broadcast reception tuner input in accordance with the requirements of the applicable regulatory authority. For example, see 47 CFR paragraph 15.111 and ANSI C63.4 paragraph 12.1.5 and Appendix H5 (test method) with the following clarifications:

- With the TV tuned to each channel [e.g., channel 2 to channel 69], the level of the local oscillator frequency and the second harmonic shall be measured and recorded for each tuner.
- Antenna-conducted power measurements shall be performed with the EUT antenna terminals connected directly to either a spectrum analyzer or another measurement instrument conforming to ANSI C63.2 or CISPR 16-1 or the latest revision thereof, if the antenna impedance matches the impedance of the measuring instrument. Otherwise, use a balun or impedance-matching network to connect the measuring instrument to the antenna terminals of the EUT. Manufacturer-supplied interconnect cabling or wiring shall be used, or if none is supplied, the cable shall be commercially available and a maximum of 2 m in length. Losses in decibels in any balun or impedance-matching network used shall be added to the measured value in dB/ μ V. The TV shall be setup as shown in Figure 8.

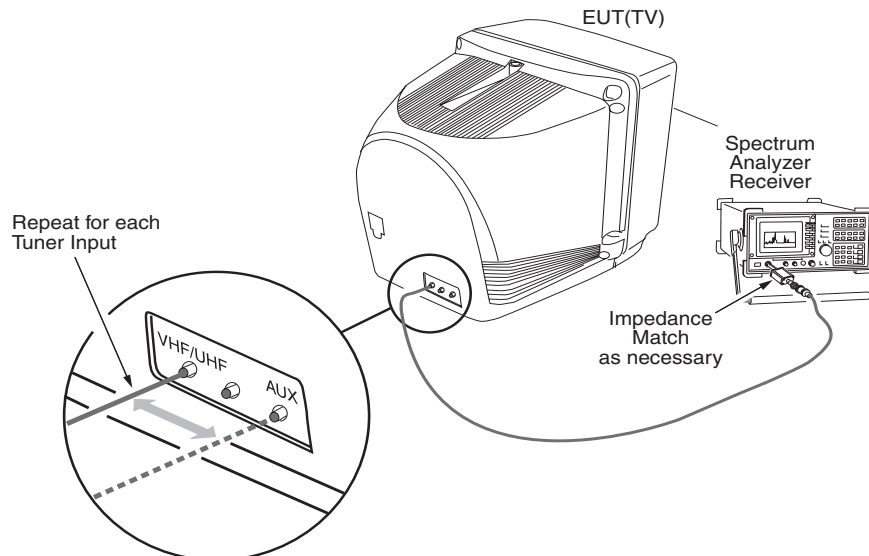

Figure 8—Test arrangement for antenna radiation

Annex A

(informative)

General TV test requirements

In addition to the emissions tests methods described in this standard, there may be several other tests required for TV broadcast receivers. The paragraphs below provide a brief description of several of these requirements.

A.1 Emissions limits

Emission limits that apply are those established by the regulatory authority that regulates the product. For example, in the United States, the limits and frequency range for conducted and radiated emissions are specified in 47 CFR Part 15.

A.2 Noise figure

Noise figure limits that apply are those established by the regulatory authority that regulates the product. For example, in the United States, 47 CFR Part 15.117(g) states that “the noise figure for any television channel 14 to 69 inclusive shall not exceed 14 dB.” FCC measurement procedure FCC/OET MP-2 entitled “Measurement of UHF Noise Figure of TV Receivers” is available from the FCC.

A.3 Peak picture sensitivity

Peak picture sensitivity that applies is that established by the regulatory authority that regulates the product. For example, in the United States, 47 CFR Part 15.117(f) states that “The picture sensitivity of a TV broadcast receiver averaged for all channels between 14 and 69 inclusive shall not be more than 8 dB larger than the peak picture sensitivity of that receiver averaged for all channels between 2 and 13.”

A.4 Selector switch isolation

Selector switch isolation specification that applies is that established by the regulatory authority that regulates the product. For example, in the United States, 47 CFR Part 15.117(g) states that “For a TV broadcast receiver equipped with a cable input selector switch, the selector shall provide in any of its set positions, isolation between the antenna and cable input terminals...” FCC measurement procedure FCC/OET MP-9 entitled “FCC Procedure for Measuring Cable Television Switch Isolation” is available from the FCC.

A.5 Cable compatibility

The cable compatibility specification that applies is that established by the regulatory authority that regulates the product. For example, in the United States, 47 CFR Part 15.118 states that “all consumer electronics TV receiving equipment marketed in the United States as cable ready or cable compatible shall comply with the provisions of this section.” Section 118 includes adjacent channel interference, image channel interference, and several other immunity requirements.

Annex B

(informative)

Bibliography

[B1] IEEE 100™, The Authoritative Dictionary of IEEE Standards Terms, Seventh Edition.^{7, 8}

[B2] IEEE 213™-1987, IEEE Standard Procedure for Measuring Conducted Emissions in the Range of 300 kHz to 25 MHz from Television and FM Broadcast Receivers to Power Lines.⁹

[B3] FCC Website. Available: <http://www.fcc.gov>.

[B4] IEEE Website. Available: <http://www.ieee.org>.

⁷The IEEE standards or products referred to in this annex are trademarks of the Institute of Electrical and Electronics Engineers, Inc.

⁸IEEE publications are available from the Institute of Electrical and Electronics Engineers, 445 Hoes Lane, P.O. Box 1331, Piscataway, NJ 08855-1331, USA (<http://standards.ieee.org/>).

⁹IEEE Std 213-1987 has been withdrawn; however, copies can be obtained from Global Engineering, 15 Inverness Way East, Englewood, CO 80112-5704, USA, tel. (303) 792-2181 (<http://global.ihs.com/>).